

# El-dampkedel / EL-STEAM

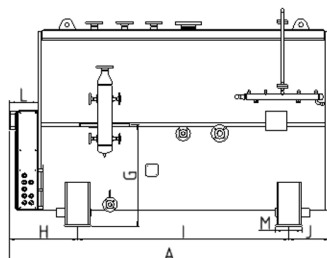

400 - 600 kW



800 - 2400 kW

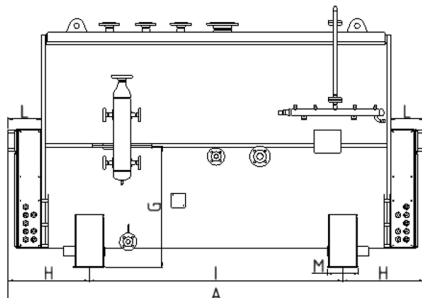

2800 - 6000 kW

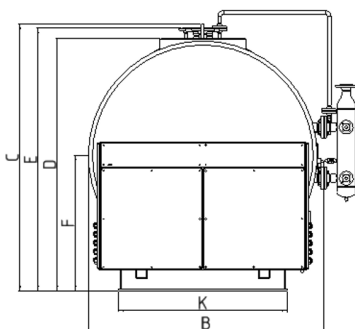
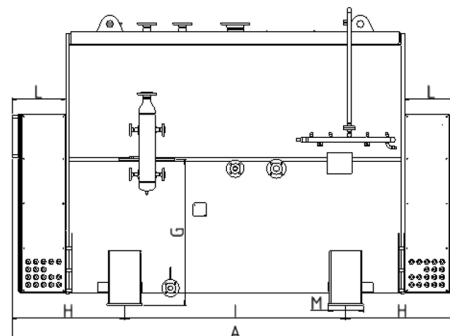

Varmelegemer		I én ende		I begge ender														
EL-STEAM	kW	400	600	800	1000	1200	1600	2000	2400	2800	3200	3600	4000	4400	4800	5200	5500	6000
Spænding	V	400	400	400	400	400	400	400	400	400	400	400						
		690	690	690	690	690	690	690	690	690	690	690	690	690	690	690	690	690
Strøm (@400V)	A	577	866	1155	1443	1732	2309	2887	3464	4041	4619	5196						
		335	502	669	837	1004	1339	1673	2008	2343	2678	3012	3347	3682	4016	4351	4602	5020
Dampydelse <sup>1</sup>	kg/h	600	900	1200	1500	1800	2400	3000	3600	4200	4800	5400	6000	6600	7200	7800	8250	9000
Min. damptryk (arbejds tryk)	Bar	3,4	7,4	6	8,2	2,3	3,6	6	7,8	6	7,2	5,7	6,5	6,5	7,3	8,1	8,8	8,3
Antal varmelegemer	stk.	8	12	16	20	24	32	40	48	56	64	72	80	88	96	104	110	120
1. indkobling (minimums effekt)	kW	50	50	50	50	50	50	50	50	50	50	50	50	50	50	50	50	50
Varmelegeme kapsling	stk.	1xL	1xL	2xL	2xL	2xL	2xL	2xL	2xL	2xS	2xS	2xS	2xS	2xS	2xS	2xS	2xS	2xS
Brutto Længde	mm	2600	2600	3200	3200	3500	3500	3500	3500	3800	3800	3800	3800	3800	3800	3800	3800	3800
Brutto Bredde	mm	1360	1360	1360	1360	1760	1760	1760	1760	2010	2010	2260	2260	2460	2460	2460	2460	2460
Brutto Højde	mm	1600	1600	1600	1600	2000	2000	2000	2000	2200	2200	2500	2500	2700	2700	2700	2700	2700
A	mm	2538	2538	3416	3416	3416	3416	3416	3416	3800	3800	3800	3800	3800	3800	3800	3800	3800
B	mm	1355	1355	1355	1355	1755	1755	1755	1755	2005	2005	2255	2255	2455	2455	2455	2455	2455
C	mm	1519	1519	1519	1519	1919	1919	1919	1919	2169	2169	2419	2419	2619	2619	2619	2619	2619
D	mm	1421	1421	1421	1421	1821	1821	1821	1821	2071	2071	2321	2321	2521	2521	2521	2521	2521
E	mm	1500	1500	1500	1500	1900	1900	1900	1900	2150	2150	2400	2400	2600	2600	2600	2600	2600
F	mm	755	755	755	755	955	955	955	955	1080	1080	1205	1205	1305	1305	1305	1305	1305
G	mm	830	867	830	830	915	915	985	985	1115	1115	1240	1240	1415	1415	1415	1415	1330
H	mm	668	668	668	668	768	768	768	768	960	960	960	960	960	960	960	960	960
I	mm	1470	1470	2080	2080	1880	1880	1880	1880	1880	1880	1880	1880	1880	1880	1880	1880	1880



Varmelegemer		I én ende		I begge ender														
EL-STEAM	kW	400	600	800	1000	1200	1600	2000	2400	2800	3200	3600	4000	4400	4800	5200	5500	6000
J	mm	400	400	400	400	500	500	500	500	500	500	500	500	500	500	500	500	500
K	mm	900	900	900	900	1250	1250	1250	1250	1500	1500	1650	1650	1850	1850	1850	1850	1850
L	mm	268	268	268	268	268	268	268	268	460	460	460	460	460	460	460	460	460
M	mm	250	250	250	250	250	250	250	250	300	300	300	300	300	300	300	300	300
Vandindhold til L.V.	m <sup>3</sup>	0,8	0,9	1	1	1,5	1,5	1,8	1,7	2,4	2,4	3,3	3,2	4,3	4,3	4,3	4,3	3,9
Damptrum ved L.V.	m <sup>3</sup>	0,6	0,5	0,7	0,7	1,9	1,9	1,7	1,7	2,3	2,3	3,2	3,2	3,5	3,5	3,5	3,5	4,2
Vægt (PS13,0 barg)	kg	3300	3400	3700	3700	4600	4700	4800	4900	5800	5900	6600	6700	7600	7700	7800	7900	8100
Total vægt (incl. Vand)	kg	4700	4800	5400	5400	8000	8100	8300	8300	10500	10600	13100	13100	15400	15500	15600	15700	16200
Power el-skab bredde <sup>2</sup>	mm	2400	2400	2400	2400	2400	2400	2400	4200	4200	4200	4200	4400	4400	4400	4400	4800	4800
Power el-skab dybde <sup>2</sup>	mm	600	600	600	600	600	600	600	600	600	600	600	600	600	600	600	600	600
Power el-skab højde <sup>2</sup>	mm	2100	2100	2100	2100	2100	2100	2100	2100	2100	2100	2100	2100	2100	2100	2100	2100	2100
Power el-skab vægt (@400V) <sup>3</sup>	kg	880	900	920	940	960	990	1020	1260	1290	1320	1590						
Power el-skab vægt (@690V) <sup>3</sup>	kg	720	740	760	780	800	825	850	1050	1075	1100	1325	1350	1575	1600	1625	1650	1675
Styre el-skab bredde <sup>4</sup>	mm	800	800	800	800	800	800	800	800	800	800	800	800	800	800	800	800	800
Styre el-skab dybde <sup>4</sup>	mm	250	250	250	250	250	250	250	250	250	250	250	250	250	250	250	250	250
Styre el-skab højde <sup>4</sup>	mm	1000	1000	1000	1000	1000	1000	1000	1000	1000	1000	1000	1000	1000	1000	1000	1000	1000
Styre el-skab vægt	kg	62	62	62	62	62	62	62	62	62	62	62	62	62	62	62	62	62
Manometer	DN	20	20	20	20	20	20	20	20	20	20	20	20	20	20	20	20	20
Luftventil	DN	20	20	20	20	20	20	20	20	20	20	20	20	20	20	20	20	20
Afsaltning / Vandprøve	DN	50	50	50	50	50	50	50	50	50	50	50	50	50	50	50	50	50
Dampventil 6,0 barg	DN	50	65	65	80	80	100	100	125	125	125	150	150	150	150	200	200	200
Dampventil 8,0 barg	DN	40	50	65	65	80	80	100	100	100	125	125	125	125	150	150	150	200
Dampventil 10,0 barg	DN	40	50	50	65	65	80	80	100	100	100	125	125	125	125	125	150	150
Dampventil 15,0 barg	DN	32	40	50	50	50	65	65	80	80	100	100	100	100	100	125	125	125
Tørkogsikring	DN	50	50	50	50	50	50	50	50	50	50	50	50	50	50	50	50	50
Høj vandstand	DN	50	50	50	50	50	50	50	50	50	50	50	50	50	50	50	50	50
Vandstandssikring	DN	50	50	50	50	50	50	50	50	50	50	50	50	50	50	50	50	50
Sikkerhedsventil 8 barg	DN	20	25	32	32	40	40	50	50	65	65	65	65	65	80	80	80	80
Sikkerhedsventil 10 barg	DN	20	25	25	32	32	40	40	50	50	50	65	65	65	65	65	65	80
Sikkerhedsventil 13 barg	DN	20	20	25	25	32	32	40	40	50	50	50	50	65	65	65	65	65
Sikkerhedsventil 16 barg	DN	20	20	25	25	25	32	32	40	40	50	50	50	50	50	65	65	65
Vandstandsflaske	DN	2 x 50	2 x 50	2 x 50	2 x 50	2 x 50	2 x 50	2 x 50	2 x 50	2 x 50	2 x 50	2 x 50	2 x 50	2 x 50	2 x 50	2 x 50	2 x 50	2 x 50
Vandstandsarmatur	DN	4 x 20	4 x 20	4 x 20	4 x 20	4 x 20	4 x 20	4 x 20	4 x 20	4 x 20	4 x 20	4 x 20	4 x 20	4 x 20	4 x 20	4 x 20	4 x 20	4 x 20
Føde- & kontraventil	DN	20	25	25	32	32	32	32	32	32	40	40	40	40	40	40	40	40
Bundventil	DN	25	25	25	25	25	32	32	32	32	32	32	32	32	32	32	32	32

- 1) Ved nominal effekt, 8barg og 100°C
- 2) Gulv tavle
- 3) Ca.
- 4) Væg tavle



400 - 1000 kW

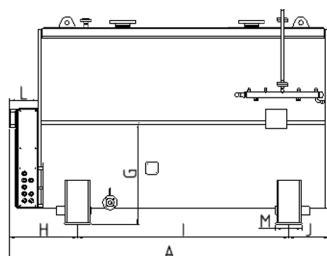

1200 - 2400 kW

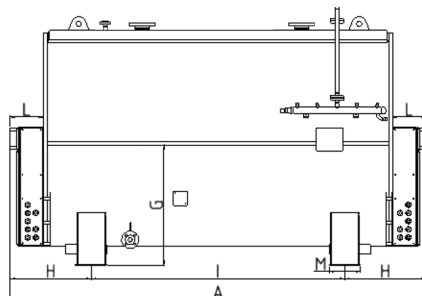

2800 - 6000 kW

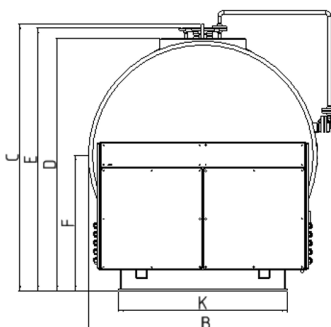
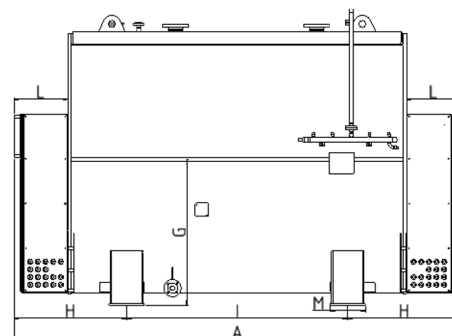

Varmelegemer		I én ende				I begge ender													
EL-HTHW/LTHW	kW	400	600	800	1000	1200	1600	2000	2400	2800	3200	3600	4000	4400	4800	5200	5500	6000	
Spænding	V	400	400	400	400	400	400	400	400	400	400	400							
		690	690	690	690	690	690	690	690	690	690	690	690	690	690	690	690	690	690
Strøm (@400V)	A	577	866	1155	1443	1732	2309	2887	3464	4041	4619	5196							
Strøm (@690V)		335	502	669	837	1004	1339	1673	2008	2343	2678	3012	3347	3682	4016	4351	4602	5020	
Antal varmelegemer	pc.	8	12	16	20	24	32	40	48	56	64	72	80	88	96	104	110	120	
1. indkobling (minimums effekt)	kW	50	50	50	50	50	50	50	50	50	50	50	50	50	50	50	50	50	50
Varmelegeme kapsling	pc.	1xL	1xL	1xL	1xL	2xL	2xL	2xL	2xL	2xS	2xS	2xS	2xS	2xS	2xS	2xS	2xS	2xS	2xS
Brutto Længde	mm	2200	2200	2200	2200	3800	3800	3800	3800	3800	3800	3800	3800	3800	3800	3800	3800	3800	3800
Brutto Bredde	mm	1310	1310	1310	1310	1310	1310	1310	1710	1710	1710	1710	1960	1960	1960	1960	1960	2060	
Brutto Højde	mm	1600	1600	1600	1600	1600	1600	1600	2000	2000	2000	2000	2200	2200	2200	2200	2200	2300	
A	mm	2110	2110	2110	2570	2570	3800	3800	3800	3800	3800	3800	3800	3800	3800	3800	3800	3800	3800
B	mm	1310	1310	1310	1310	1310	1310	1310	1310	1710	1710	1710	1710	1960	1960	1960	1960	1960	1960
C	mm	1569	1519	1519	1519	1519	1519	1519	1519	1919	1919	1919	1919	2169	2169	2169	2169	2169	2169
D	mm	1421	1421	1421	1421	1421	1421	1421	1421	1821	1821	1821	1821	2071	2071	2071	2071	2071	2071
E	mm	1500	1500	1500	1500	1500	1500	1500	1500	1900	1900	1900	1900	2150	2150	2150	2150	2150	2150
F	mm	755	755	755	755	755	755	755	755	955	955	955	955	1080	1080	1080	1080	1080	1080
H	mm	860	860	860	860	860	860	860	860	960	960	960	960	960	960	960	960	960	960



Varmelegemer		I én ende				I begge ender													
EL-HTHW/LTHW	kW	400	600	800	1000	1200	1600	2000	2400	2800	3200	3600	4000	4400	4800	5200	5500	6000	
I	mm	850	850	850	850	850	2080	2080	2080	1880	1880	1880	1880	1880	1880	1880	1880	1880	
J	mm	400	400	400	400	400	400	400	400	500	500	500	500	500	500	500	500	500	
K	mm	900	900	900	900	900	900	900	900	1250	1250	1250	1250	1500	1500	1500	1500	1500	
L	mm	460	460	460	460	460	460	460	460	460	460	460	460	460	460	460	460	460	
M	mm	250	250	250	250	250	250	250	250	250	250	250	250	300	300	300	300	300	
Total volumen	m <sup>3</sup>	0,9	0,9	0,9	0,9	2,3	2,3	2,3	3,4	3,4	3,4	3,4	4,7	4,7	4,7	4,7	4,7	5,6	
Vægt (PS13,0 barg)	kg	3700	3700	3700	3700	4100	4100	4100	5300	5300	5300	5300	6200	6200	6200	6200	6200	7000	
Total vægt (incl. Vand)	kg	4600	4600	4600	4600	6400	6400	6400	8700	8700	8700	8700	10900	10900	10900	10900	10900	12600	
Power el-skab bredde <sup>2</sup>	mm	2400	2400	2400	2400	2400	2400	2400	4200	4200	4200	4200	4400	4400	4400	4400	4800	4800	
Power el-skab dybde <sup>2</sup>	mm	600	600	600	600	600	600	600	600	600	600	600	600	600	600	600	600	600	
Power el-skab højde <sup>2</sup>	mm	2100	2100	2100	2100	2100	2100	2100	2100	2100	2100	2100	2100	2100	2100	2100	2100	2100	
Power el-skab vægt (@400V) <sup>3</sup>	kg	880	900	920	940	960	990	1020	1260	1290	1320	1590							
Power el-skab vægt (@690V) <sup>3</sup>	kg	720	740	760	780	800	825	850	1050	1075	1100	1325	1350	1575	1600	1625	1650	1700	
Styre el-skab bredde <sup>4</sup>	mm	800	800	800	800	800	800	800	800	800	800	800	800	800	800	800	800	800	
Styre el-skab dybde <sup>4</sup>	mm	250	250	250	250	250	250	250	250	250	250	250	250	250	250	250	250	250	
Styre el-skab højde <sup>4</sup>	mm	1000	1000	1000	1000	1000	1000	1000	1000	1000	1000	1000	1000	1000	1000	1000	1000	1000	
Styre el-skab vægt	kg	62	62	62	62	62	62	62	62	62	62	62	62	62	62	62	62	62	
Manometer	DN	20	20	20	20	20	20	20	20	20	20	20	20	20	20	20	20	20	
Luftventil	DN	20	20	20	20	20	20	20	20	20	20	20	20	20	20	20	20	20	
Flowstuds frem/retur	DN	40	50	50	65	65	80	80	100	100	100	100	125	125	125	125	125	200	
Bundventil	DN	25	25	25	25	25	32	32	32	32	32	32	32	32	32	32	40	40	
Sikkerhedsventil 8 barg	DN	20	25	32	32	40	40	50	50	65	65	65	65	65	80	80	80	80	
Sikkerhedsventil 10 barg	DN	20	25	25	32	32	40	40	50	50	50	65	65	65	65	65	65	80	
Sikkerhedsventil 13 barg	DN	20	20	25	32	32	32	40	40	50	50	50	50	65	65	65	65	65	
Sikkerhedsventil 16 barg	DN	20	20	25	25	25	32	32	40	40	50	50	50	50	50	65	65	65	

- 1) At nominal effect, 8 barg and 100°C
- 2) Floor installed cabinet
- 3) Approx.
- 4) Wall installed cabinet