

Electric Steam boiler / EL-STEAM

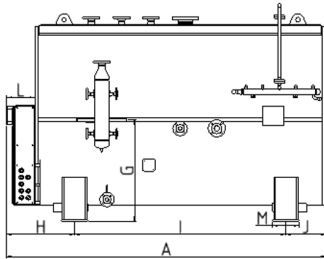

200 - 600 kW



800 - 2400 kW

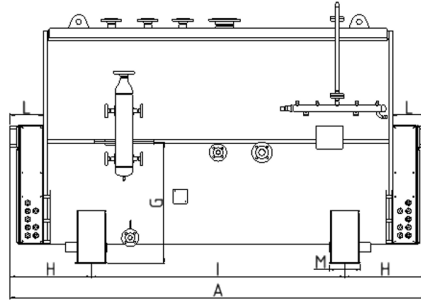

2800 - 6000 kW

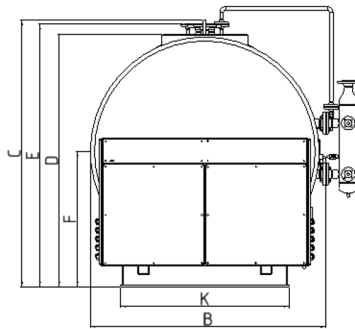
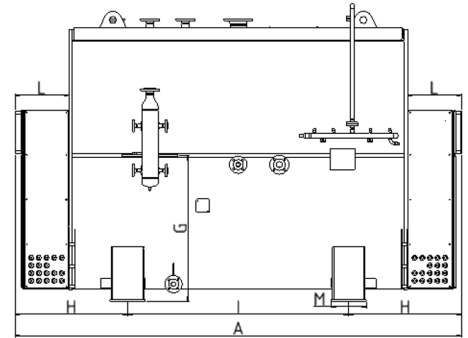

Heating element		Single side		Double side														
EL-STEAM	kW	400	600	800	1000	1200	1600	2000	2400	2800	3200	3600	4000	4400	4800	5200	5500	6000
Voltage	V	400	400	400	400	400	400	400	400	400	400	400						
		690	690	690	690	690	690	690	690	690	690	690	690	690	690	690	690	690
Current (@400V)	A	577	866	1155	1443	1732	2309	2887	3464	4041	4619	5196						
Current (@690V)		335	502	669	837	1004	1339	1673	2008	2343	2678	3012	3347	3682	4016	4351	4602	5020
Steam rating ¹	kg/h	600	900	1200	1500	1800	2400	3000	3600	4200	4800	5400	6000	6600	7200	7800	8250	9000
Min. working pressure	Bar	3,4	7,4	6	8,2	2,3	3,6	6	7,8	6	7,2	5,7	6,5	6,5	7,3	8,1	8,8	8,3
Heating elements	pcs..	8	12	16	20	24	32	40	48	56	64	72	80	88	96	104	110	120
Switching (min. effect)	kW	50	50	50	50	50	50	50	50	50	50	50	50	50	50	50	50	50
Steps (alternation)	pcs.	1xL	1xL	2xL	2xL	2xL	2xL	2xL	2xL	2xS	2xS	2xS	2xS	2xS	2xS	2xS	2xS	2xS
Heating element cabinet	mm	2600	2600	3200	3200	3500	3500	3500	3500	3800	3800	3800	3800	3800	3800	3800	3800	3800
Gross lenght	mm	1360	1360	1360	1360	1760	1760	1760	1760	2010	2010	2260	2260	2460	2460	2460	2460	2460
Gross width	mm	1600	1600	1600	1600	2000	2000	2000	2000	2300	2300	2500	2500	2700	2700	2700	2700	2700
Gross height	mm	2538	2538	3416	3416	3416	3416	3416	3416	3800	3800	3800	3800	3800	3800	3800	3800	3800
A	mm	1355	1355	1355	1355	1755	1755	1755	1755	2005	2005	2255	2255	2455	2455	2455	2455	2450
B	mm	1569	1569	1569	1569	1969	1969	1969	1969	2219	2219	2469	2469	2669	2669	2669	2669	2619
C	mm	1412	1412	1412	1412	1812	1812	1812	1812	2062	2062	2312	2312	2512	2512	2512	2512	2521
D	mm	1500	1500	1500	1500	1900	1900	1900	1900	2150	2150	2400	2400	2600	2600	2600	2600	2600
E	mm	755	755	755	755	955	955	955	955	1080	1080	1205	1205	1305	1305	1305	1305	1305
F	mm	830	867	830	830	915	915	985	985	1115	1115	1240	1240	1415	1415	1415	1415	1415
G	mm	668	668	668	668	768	768	768	768	960	960	960	960	960	960	960	960	960
H	mm	668	668	668	668	768	768	768	768	960	960	960	960	960	960	960	960	

Electric Steam boiler / EL-STEAM



Heating element		Single side		Double side															
EL-STEAM	kW	400	600	800	1000	1200	1600	2000	2400	2800	3200	3600	4000	4400	4800	5200	5500	6000	
I	mm	1470	1470	2080	2080	2080	2080	2080	2080	2080	2080	2080	2080	2080	2080	2080	2080	2080	1880
J	mm	400	400	400	400	500	500	500	500	500	500	500	500	500	500	500	500	500	500
K	mm	900	900	900	900	1250	1250	1250	1250	1500	1500	1650	1650	1850	1850	1850	1850	1850	1850
L	mm	268	268	268	268	268	268	268	268	460	460	460	460	460	460	460	460	460	460
M	mm	250	250	250	250	250	250	250	250	300	300	300	300	300	300	300	300	300	300
Water content to L.W.	m ³	0,8	0,8	1	1	1,5	1,5	1,8	1,7	2,4	2,4	3,3	3,2	4,3	4,3	4,3	4,3	4,3	3,9
Steamroom at L.W.	m ³	0,6	0,5	0,7	0,7	1,9	1,9	1,7	1,7	2,3	2,3	3,2	3,2	3,5	3,5	3,5	3,5	3,5	4,2
Weight (PS13,0 barg)	kg	3300	3400	3700	3700	4600	4700	4800	4900	5800	5900	6600	6700	7600	7700	7800	7900	8100	8100
Total weight (incl. water)	kg	4700	4700	5400	5400	8000	8100	8300	8300	10500	10600	13100	13100	15400	15500	15600	15700	16200	16200
Power cabinet width ²	mm	2400	2400	2400	2400	2400	2400	2400	4200	4200	4200	4200	4400	4400	4400	4400	4800	4800	4800
Power cabinet depth ²	mm	600	600	600	600	600	600	600	600	600	600	600	600	600	600	600	600	600	600
Power cabinet height ²	mm	2100	2100	2100	2100	2100	2100	2100	2100	2100	2100	2100	2100	2100	2100	2100	2100	2100	2100
Power cabinet weight (@400V) ³	kg	880	900	920	940	960	990	1020	1260	1290	1320	1590							
Power cabinet weight (@690V) ³	kg	800	850	900	925	950	970	1200	1450	1500	1650	1700	1750	1800	1850	1900	1950	2000	2000
Control cabinet width ⁴	mm	600	600	600	600	600	600	600	600	600	600	600	600	600	600	600	600	600	600
Control cabinet depth ⁴	mm	250	250	250	250	250	250	250	250	250	250	250	250	250	250	250	250	250	250
Control cabinet height ⁴	mm	1000	1000	1000	1000	1000	1000	1000	1000	1000	1000	1000	1000	1000	1000	1000	1000	1000	1000
Control cabinet weight	kg	62	62	62	62	62	62	62	62	62	62	62	62	62	62	62	62	62	62
Manometer	DN	20	20	20	20	20	20	20	20	20	20	20	20	20	20	20	20	20	20
Airvalve	DN	20	20	20	20	20	20	20	20	20	20	20	20	20	20	20	20	20	20
Desalting / watertest	DN	50	50	50	50	50	50	50	50	50	50	50	50	50	50	50	50	50	50
Steam valve 6,0 barg	DN	50	65	65	80	80	100	100	125	125	125	150	150	150	150	200	200	200	200
Steam valve 8,0 barg	DN	40	50	65	65	80	80	100	100	100	125	125	125	125	150	150	150	150	150
Steam valve 10,0 barg	DN	40	50	50	65	65	80	80	100	100	100	125	125	125	125	125	150	150	150
Steam valve 15,0 barg	DN	32	40	50	50	50	65	65	80	80	100	100	100	100	100	125	125	125	125
Low level electrode	DN	50	50	50	50	50	50	50	50	50	50	50	50	50	50	50	50	50	50
High level electrode	DN	50	50	50	50	50	50	50	50	50	50	50	50	50	50	50	50	50	50
Water level safety	DN	50	50	50	50	50	50	50	50	50	50	50	50	50	50	50	50	50	50
Safety valve 8 barg	DN	20	25	32	32	40	40	50	50	65	65	65	65	65	80	80	80	80	80
Safety valve 10 barg	DN	20	25	25	32	32	40	40	50	50	50	65	65	65	65	65	65	65	65
Safety valve 13 barg	DN	20	20	25	25	32	32	40	40	50	50	50	50	65	65	65	65	65	65
Safety valve 18 barg	DN	20	20	20	25	25	32	32	40	40	40	50	50	50	50	50	65	65	65
Watergauge bottle	DN	2 x 50	2 x 50	2 x 50	2 x 50	2 x 50	2 x 50	2 x 50	2 x 50	2 x 50	2 x 50	2 x 50	2 x 50	2 x 50	2 x 50	2 x 50	2 x 50	2 x 50	2 x 50
Safety watergauge mountings	DN	4 x 20	4 x 20	4 x 20	4 x 20	4 x 20	4 x 20	4 x 20	4 x 20	4 x 20	4 x 20	4 x 20	4 x 20	4 x 20	4 x 20	4 x 20	4 x 20	4 x 20	4 x 20
Feed & counter valves	DN	20	25	25	32	32	32	32	32	32	40	40	40	40	40	40	40	40	40
Blow down valve	DN	25	25	25	25	25	32	32	32	32	32	32	32	32	32	32	32	32	32

- 1) At nominal effect, 8 barg and 100°C
- 2) Floor installed cabinet
- 3) Approx.
- 4) Wall installed cabinet

High Temperature Hot Water boiler / EL-HTHW Low Temperature Hot Water boiler / EL-LTHW



200 - 1000 kW

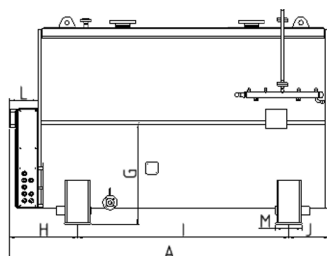

1200 - 2400 kW

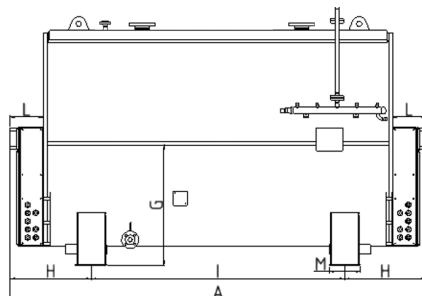

2800 - 6000 kW

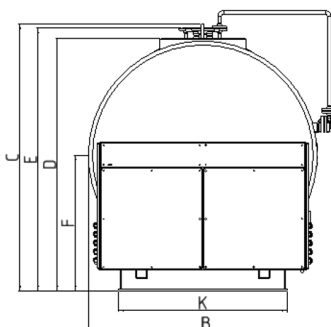
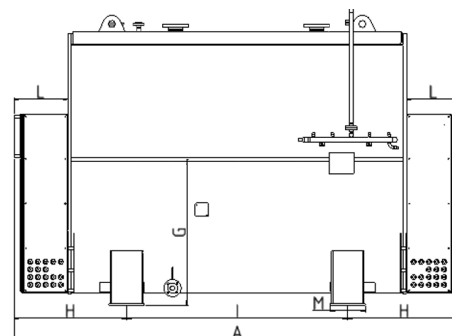

Heating element		Single side								Double side									
EL-HTHW/LTHW	kW	400	600	800	1000	1200	1600	2000	2400	2800	3200	3600	4000	4400	4800	5200	5500	6000	
Voltage	V	400	400	400	400	400	400	400	400	400	400	400							
		690	690	690	690	690	690	690	690	690	690	690	690	690	690	690	690	690	690
Current (@400V)	A	577	866	1155	1443	1732	2309	2887	3464	4041	4619	5196							
Current (@690V)		335	502	669	837	1004	1339	1673	2008	2343	2678	3012	3347	3682	4016	4351	4602	5020	
Heating elements	pc.	8	12	16	20	24	32	40	48	56	64	72	80	88	96	104	110	120	
Switching (min. effect)	kW	50	50	50	50	50	50	50	50	50	50	50	50	50	50	50	50	50	
Heating element cabinet	pc.	1xL	1xL	1xL	1xL	2xL	2xL	2xL	2xL	2xS	2xS	2xS	2xS	2xS	2xS	2xS	2xS	2xS	
Gross length	mm	2200	2200	2200	2200	3800	3800	3800	3800	3800	3800	3800	3800	3800	3800	3800	3800	3800	
Gross width	mm	1310	1310	1310	1310	1310	1310	1310	1710	1710	1710	1710	1960	1960	1960	1960	1960	1960	
Gross height	mm	1600	1600	1600	1600	1600	1600	2000	2000	2000	2000	2000	2200	2200	2200	2200	2200	2700	
A	mm	2110	2110	2570	2570	3800	3800	3800	3800	3800	3800	3800	3800	3800	3800	3800	3800	3800	
B	mm	1310	1310	1310	1310	1310	1310	1310	1710	1710	1710	1710	1960	1960	1960	1960	1960	1960	
C	mm	1519	1519	1519	1519	1519	1519	1519	1919	1919	1919	1919	2169	2169	2169	2169	2169	2669	
D	mm	1421	1421	1421	1421	1421	1421	1421	1821	1821	1821	1821	2071	2071	2071	2071	2071	2521	
E	mm	1500	1500	1500	1500	1500	1500	1500	1500	1900	1900	1900	2150	2150	2150	2150	2150	2600	
F	mm	755	755	755	755	755	755	755	955	955	955	955	955	1080	1080	1080	1080	1305	
H	mm	860	860	860	860	860	860	860	960	960	960	960	960	960	960	960	960	960	

High Temperature Hot Water boiler / EL-HTHW

Low Temperature Hot Water boiler / EL-LTHW



Heating element		Single side				Double side													
EL-HTHW/LTHW	kW	400	600	800	1000	1200	1600	2000	2400	2800	3200	3600	4000	4400	4800	5200	5500	6000	
I	mm	850	850	850	850	2080	2080	2080	1880	1880	1880	1880	1880	1880	1880	1880	1880	1880	
J	mm	400	400	400	400	400	400	400	500	500	500	500	500	500	500	500	500	500	
K	mm	900	900	900	900	900	900	900	1250	1250	1250	1250	1500	1500	1500	1500	1500	1850	
L	mm	460	460	460	460	460	460	460	460	460	460	460	460	460	460	460	460	460	
M	mm	250	250	250	250	250	250	250	250	250	250	250	300	300	300	300	300	300	
Water content to L.W.	m ³	0,9	0,9	0,9	0,9	2,3	2,3	2,3	3,4	3,4	3,4	3,4	4,7	4,7	4,7	4,7	4,7	4,7	
Weight (PS13,0 barg)	kg	3700	3700	3700	3700	4100	4100	4100	5300	5300	5300	5300	6200	6200	6200	6200	6200	7600	
Total weight (incl. water)	kg	4600	4600	4600	4600	6400	6400	6400	8700	8700	8700	8700	10900	10900	10900	10900	10900	10900	
Power cabinet width ²	mm	2400	2400	2400	2400	2400	2400	2400	4200	4200	4200	4200	4400	4400	4400	4400	4800	4800	
Power cabinet depth ²	mm	600	600	600	600	600	600	600	600	600	600	600	600	600	600	600	600	600	
Power cabinet height ²	mm	2100	2100	2100	2100	2100	2100	2100	2100	2100	2100	2100	2100	2100	2100	2100	2100	2100	
Power cabinet weight (@400V) ³	kg	880	900	920	940	960	990	1020	1260	1290	1320	1590							
Power cabinet weight (@690V) ³	kg	800	850	900	925	950	970	1200	1450	1500	1650	1700	1750	1800	1850	1900	1950	2000	
Control cabinet width ⁴	mm	600	600	600	600	600	600	600	600	600	600	600	600	600	600	600	600	600	
Control cabinet depth ⁴	mm	250	250	250	250	250	250	250	250	250	250	250	250	250	250	250	250	250	
Control cabinet height ⁴	mm	1000	1000	1000	1000	1000	1000	1000	1000	1000	1000	1000	1000	1000	1000	1000	1000	1000	
Control cabinet weight	kg	62	62	62	62	62	62	62	62	62	62	62	62	62	62	62	62	62	
Manometer	DN	20	20	20	20	20	20	20	20	20	20	20	20	20	20	20	20	20	
Airvalve	DN	20	20	20	20	20	20	20	20	20	20	20	20	20	20	20	20	20	
Connection flow/return	DN	40	50	50	65	65	80	80	100	100	100	100	125	125	125	125	125	200	
Drain valve	DN	25	25	25	25	25	32	32	32	32	32	32	32	32	32	32	40	40	
Safety valve 8 barg	DN	20	25	32	32	40	40	50	50	65	65	65	65	65	80	80	80	80	
Safety valve 10 barg	DN	20	25	25	32	32	40	40	50	50	50	65	65	65	65	65	65	80	
Safety valve 13 barg	DN	20	20	25	32	32	32	40	40	50	50	50	50	65	65	65	65	65	
Safety valve 16 barg	DN	20	20	25	25	25	32	32	40	40	50	50	50	50	65	65	65	65	

- 1) At nominal effect, 8 barg and 100°C
- 2) Floor installed cabinet
- 3) Approx.
- 4) Wall installed cabinet